

fit^{uk}

Air Control Innovation

Energy In Catering

- 50% of the cost of a meal bought in a restaurant is attributed to the cost of energy (Source: EDF Energy)
- 30% of this energy cost is taken up by kitchen ventilation alone
- Energy costs in Europe range from 4p to 15p per kWh

Questions

- Why run fans at maximum speed when there is little or no cooking activity in the kitchen?
- When do I need to run fans at maximum speed?
- How can I avoid wasting energy and save money?
- How can I improve the efficiency of my extract systems?
- Is there a way of monitoring and managing my energy usage?
- Is my kitchen meeting current safety legislation?

Answers

- Most kitchen extract volumes are based on the equipment loads under the hood or face velocity methods based on the size of the hood/canopy
- Use intelligent controls and sensors to detect when cooking activity is taking place
- Automatically determine the periods of maximum activity, this is the only time maximum fan speed is needed
- The majority of the time the fans will run at 30-50%
- Remote access monitoring will give consumption data at your fingertips
- Flow measurement will give vital system information
- Install gas safety shut off system

The Energy Control System

- Energy Control System is designed specifically for catering areas
- Automatic fan control and modulation
- Determined by cooking activity under hood
- Sensors detect heat and smoke
- Signals sent to inverter drives
- Fans only run at maximum speed when needed
- Reducing energy consumption and cooling/heating losses
- Improving space comfort conditions

- Flow Measurement
 - Electronic measurement and display
- Gas safety protection
 - Where gas isolation is a requirement
- Energy monitoring facility for all areas of kitchen
 - Connection to incoming power supply can be monitored and logged
- Remote access for monitoring and system adjustment
 - Through GSM modem built into the system, dial in and access data, change settings if needed
- Optional built in Data Acquisition System for remote data logging

Financial Benefits

- Up to 60% saving on fan energy costs
- Up to 40% saving on heating and cooling costs/losses
 - Kitchens which are air conditioned usually send expensive conditioned air straight out through the canopy.
 - To maintain the kitchen balance the supply fan speed is reduced with the extract, so reducing the amount of air needed to be cooled/heated.
- Reduced Maintenance, fan belts are less likely to break due to lower loading
- Increased Fan Motor Life, soft start and lower overall fan speeds reduce loads and wear on the fan motors

Energy Saving Estimate

Energy Savings Analysis

Client: **Yates** Engineer: **BOC**
Site: **Birmingham - Metropole (Main Kitchen)** Date: **11/03/2008**

Extract Fan Motor Size (kW) = **15** Claims Cost for Economy controls = **£ 88**
 Extract Fan Motor Efficiency (%) = **90%** Claims Cost for Gas pitback = **£ 364**
 Supply Fan Motor Size (kW) = **4** Heating Design based on = **100 W / m²**
 Supply Fan Motor Efficiency (%) = **90%** Cooling Design based on = **100 W / m²**
 Extract Fan Design Volume (m³/s) = **10** Heating factor = **0.5**
 Supply Fan Design Volume (m³/s) = **4** Cooling factor = **0.5**
 Operating Hours Per Day = **10**
 Operating Days Per Week = **5**
 Operating Hours Per Year = **4900**

Extract Fan

| VARIABLE EXTRACT FAN VOLUME ANALYSIS | | | | | | | |
|--|------------|------------|----------|----------|--------|----------|---------------|
| % Run | % Run Time | VAV Output | MOTOR kW | TOTAL kW | System | Input kW | SAVINGS |
| BT 100% | 100 | 1 | 15 | 15 | 1.00 | 15.000 | 4808.0 |
| TOTAL KW/YEAR CALCULATION ON VARIOUS RUN TIMES | | | | | | | |
| 100 | 100 | 1.000 | 15.000 | 15.000 | 1.00 | 15.000 | 907.8 |
| 90 | 90 | 0.720 | 10.800 | 10.800 | 1.00 | 10.800 | 716.9 |
| 80 | 80 | 0.640 | 9.600 | 9.600 | 1.00 | 9.600 | 607.2 |
| 70 | 70 | 0.560 | 8.400 | 8.400 | 1.00 | 8.400 | 517.3 |
| 60 | 60 | 0.480 | 7.200 | 7.200 | 1.00 | 7.200 | 427.4 |
| 50 | 50 | 0.400 | 6.000 | 6.000 | 1.00 | 6.000 | 337.5 |
| 40 | 40 | 0.320 | 4.800 | 4.800 | 1.00 | 4.800 | 247.6 |
| 30 | 30 | 0.240 | 3.600 | 3.600 | 1.00 | 3.600 | 157.7 |
| 20 | 20 | 0.160 | 2.400 | 2.400 | 1.00 | 2.400 | 67.8 |
| 10 | 10 | 0.080 | 1.200 | 1.200 | 1.00 | 1.200 | -17.1 |
| TOTAL | | | | | | | 3086.2 |
| Average % | 80.0 | | | | | | SAVINGS 294.4 |

Supply Fan

| VARIABLE SUPPLY FAN VOLUME ANALYSIS - Cooling Design | | | | | | | |
|--|------------|------------|-----------|----------|--------|----------|----------------|
| % Run | % Run Time | VAV Output | ACTUAL kW | TOTAL kW | System | Input kW | SAVINGS |
| BT 100% | 100 | 1 | 4 | 4 | 1.00 | 4.000 | 7181.25 |
| TOTAL KW/YEAR CALCULATION ON VARIOUS RUN TIMES | | | | | | | |
| 100 | 100 | 1.000 | 4.000 | 4.000 | 1.00 | 4.000 | 1561.65 |
| 90 | 90 | 0.720 | 2.880 | 2.880 | 1.00 | 2.880 | 905.07 |
| 80 | 80 | 0.640 | 2.560 | 2.560 | 1.00 | 2.560 | 644.22 |
| 70 | 70 | 0.560 | 2.240 | 2.240 | 1.00 | 2.240 | 553.37 |
| 60 | 60 | 0.480 | 1.920 | 1.920 | 1.00 | 1.920 | 462.52 |
| 50 | 50 | 0.400 | 1.600 | 1.600 | 1.00 | 1.600 | 371.67 |
| 40 | 40 | 0.320 | 1.280 | 1.280 | 1.00 | 1.280 | 280.82 |
| 30 | 30 | 0.240 | 0.960 | 0.960 | 1.00 | 0.960 | 189.97 |
| 20 | 20 | 0.160 | 0.640 | 0.640 | 1.00 | 0.640 | 99.12 |
| 10 | 10 | 0.080 | 0.320 | 0.320 | 1.00 | 0.320 | 8.27 |
| TOTAL | | | | | | | 4713.83 |
| | | | | | | | SAVINGS 294.42 |

| VARIABLE EXTRACT FAN VOLUME ANALYSIS - Heating Design | | | | | | | |
|---|------------|------------|-----------|----------|--------|----------|-----------------|
| % Run | % Run Time | VAV Output | ACTUAL kW | TOTAL kW | System | Input kW | SAVINGS |
| BT 100% | 100 | 1 | 4 | 4 | 1.00 | 4.000 | 10384.00 |
| TOTAL KW/YEAR CALCULATION ON VARIOUS RUN TIMES | | | | | | | |
| 100 | 100 | 1.000 | 4.000 | 4.000 | 1.00 | 4.000 | 1876.40 |
| 90 | 90 | 0.720 | 2.880 | 2.880 | 1.00 | 2.880 | 1111.76 |
| 80 | 80 | 0.640 | 2.560 | 2.560 | 1.00 | 2.560 | 947.52 |
| 70 | 70 | 0.560 | 2.240 | 2.240 | 1.00 | 2.240 | 783.28 |
| 60 | 60 | 0.480 | 1.920 | 1.920 | 1.00 | 1.920 | 619.04 |
| 50 | 50 | 0.400 | 1.600 | 1.600 | 1.00 | 1.600 | 454.80 |
| 40 | 40 | 0.320 | 1.280 | 1.280 | 1.00 | 1.280 | 290.56 |
| 30 | 30 | 0.240 | 0.960 | 0.960 | 1.00 | 0.960 | 126.32 |
| 20 | 20 | 0.160 | 0.640 | 0.640 | 1.00 | 0.640 | 62.08 |
| 10 | 10 | 0.080 | 0.320 | 0.320 | 1.00 | 0.320 | -2.16 |
| TOTAL | | | | | | | 7081.51 |
| | | | | | | | SAVINGS 3343.49 |

Conditioned air losses

Cooling

Cooling season May to September
 Operating Days May to September = **163**
 Operating Hours May to September = **2794**
 Energy required to cool for 1% of air flow = **£ 63466**
 Cost to cool for 1% per annum (based on operating days & cooling factor) = **£ 520**
 Cost to cool extract air volume per annum (based on operating days & cooling factor) = **£ 7.851**
 On average extract fan running 60.0% Savings = 30.0% Equating to a saving of **£ 2.148** per annum

Heating

Heating season October to April
 Operating Days October to April = **272**
 Operating Hours October to April = **3016**
 Energy required to heat for 1% of air flow = **£ 26046**
 Cost to heat for 1% per annum (based on operating days & heating factor) = **£ 1.000**
 Cost to heat extract air volume per annum (based on operating days & heating factor) = **£ 10.140**
 On average extract fan running 60.0% Savings = 30.0% Equating to a saving of **£ 3.200** per annum

Install Hood savings therefore:

| | |
|----------------------|-----------------|
| Extract fan | £ 2,896 |
| Supply fan - cooling | £ 264 |
| Supply fan - heating | £ 300 |
| Cooling losses | £ 2,746 |
| Heating losses | £ 5,200 |
| TOTAL SAVINGS | £ 11,573 |

Total cost for the supply, installation, commissioning and monitoring of the system **£ 13,200**

Total estimated savings **£ 11,573**
 Payback Period 0.9 years **1.07**

Affinity Laws

| Speed | Volume | Power/kW required |
|-------|--------|-------------------|
| 100% | 100% | 100% |
| 90% | 90% | 73% |
| 80% | 80% | 51% |
| 70% | 70% | 34% |
| 60% | 60% | 22% |
| 50% | 50% | 13% |
| 40% | 40% | 6% |
| 30% | 30% | 3% |

Typical Energy Consumption Graph

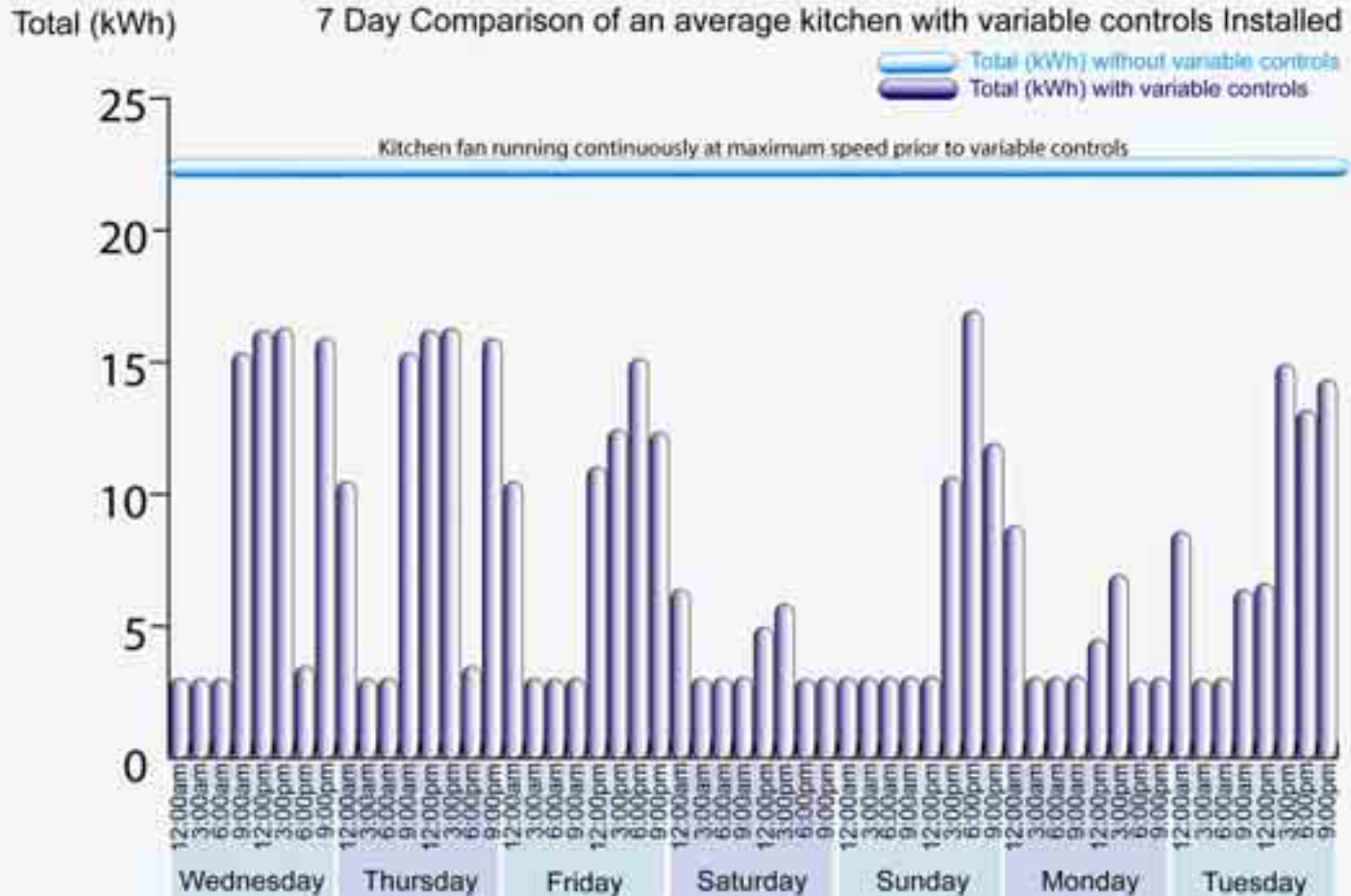

Schematic Layout

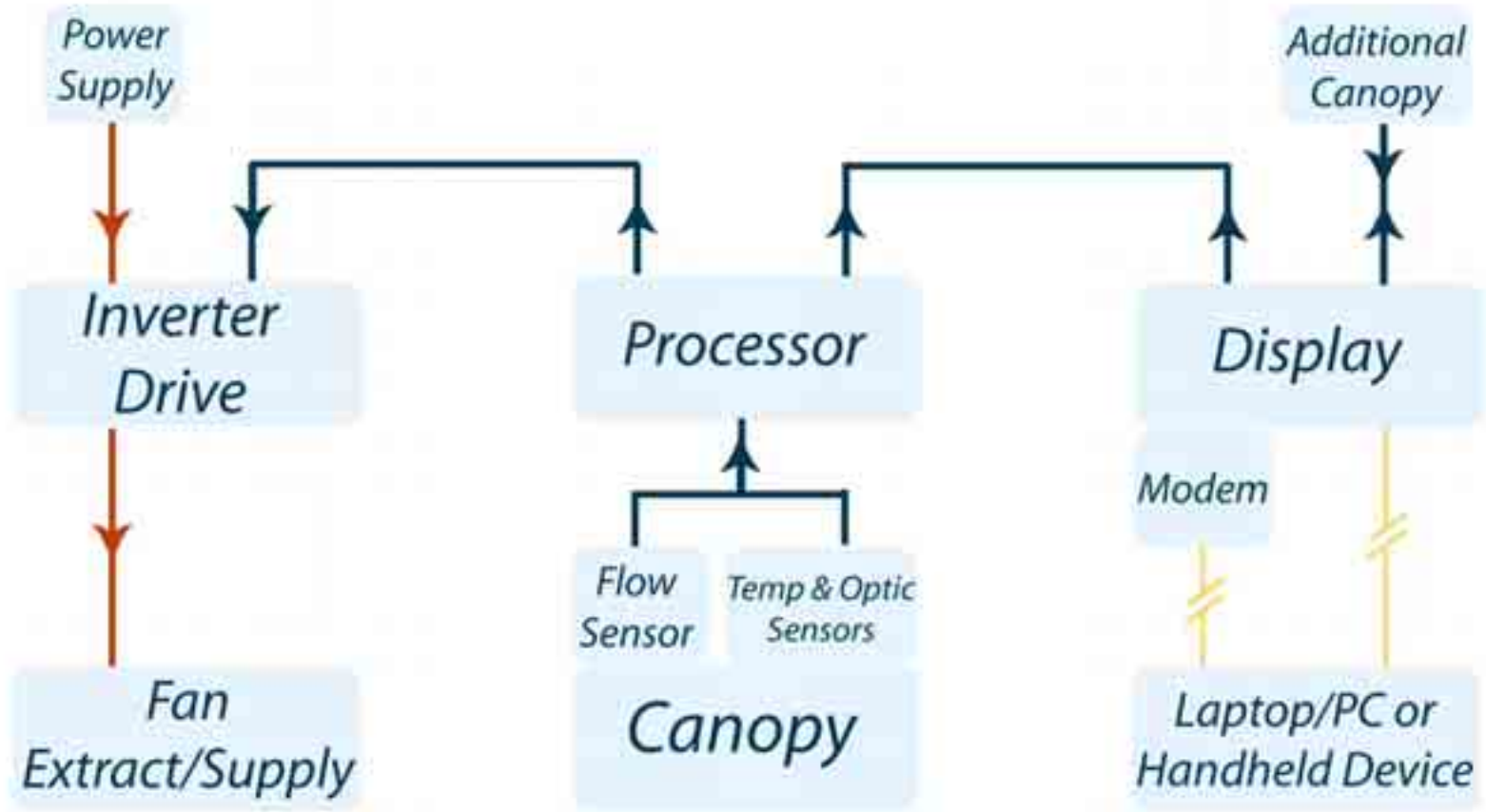

Typical Configuration

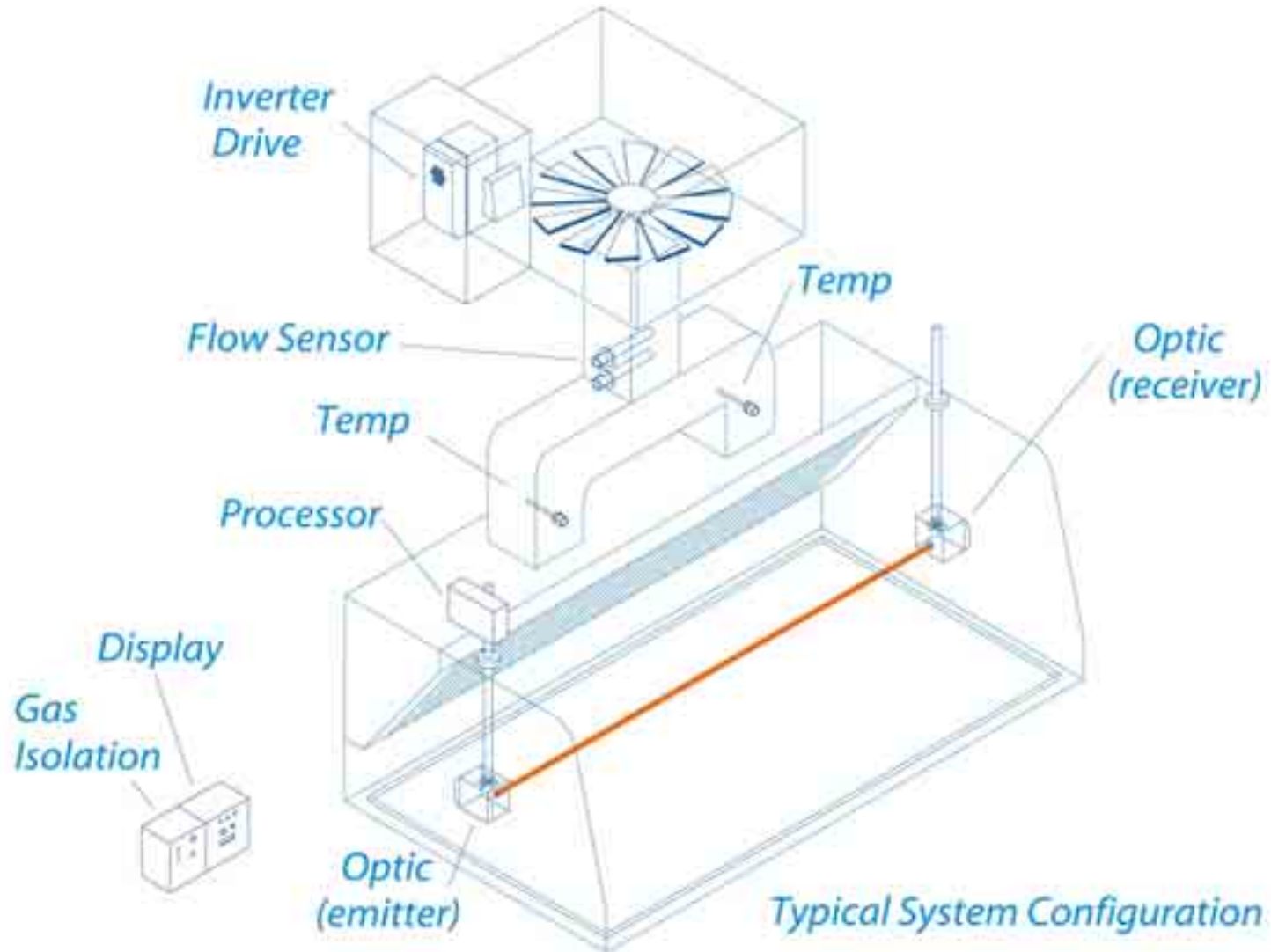

Operational Benefits

- Flow measurement – visual confirmation that design flows are being achieved, no broken belts, blocked filters or closed dampers, so optimising fan duty
- Remote early warning of ventilation faults
- Online fan speed profile
- Remote interrogation of system operation and adjustment if needed
- Area energy consumption monitoring
- Gas safety shut off in event of fan failure

Installation Process

- Fitting of optical sensors inside the hood
- Fitting of temperature sensors in duct
- Fitting of velocity probes in duct (where required)
- Mounting of display in kitchen area
- Connection of processor units to hoods
- Plug in cable connections and cable run to motors
- Wiring of inverter drives to power and motors
- Set up and commissioning through laptop or handheld device

- The installation process takes 4-6 hours and will normally be undertaken out of cooking hours

Frequently Asked Questions

- Maintenance – little needed by on-site personnel
- Troubleshooting – display and online diagnostics
- Component failure – fans override to 100%
- Cleaning – general good housekeeping as with hoods
- Calibration – self calibrating
- Monitoring – data loggers fitted randomly

Conclusion

- Maximum design extract volume is only needed at times of maximum cooking activity
- When all equipment under the hood is at maximum output
 - This only occurs for short periods of the day
- The requirement for cooling and heating of air can be significantly reduced
- Where kitchen extract and supply fans run from 12 to 24 hours per day, substantial savings can be made through fitting the Energy Control System